



# **Interconnection Feasibility Study Report GIP-IR626-FEAS-R1**

**Generator Interconnection Request 626  
100 MW Wind Generating Facility  
Pictou County, NS**

2022-01-14

Control Centre Operations  
Nova Scotia Power Inc.

### Executive Summary

The Interconnection Customer (IC) submitted an Interconnection Request (IR#626) for Network Resource Interconnection Service (NRIS) for a proposed 100 MW wind generation facility interconnected to the NSPI transmission system, with a Commercial Operation Date of 2024-01-01. The Point of Interconnection (POI) requested by the customer is the 230kV line L-7003, approximately 67.8 km from 3C-Port Hastings substation.

There are four transmission and three distribution Interconnection Requests currently in the Advanced Stage Transmission and Distribution Queue that must be included in the study models for IR#626. In addition, there is one long-term firm transmission service reservation in the amount of 800 MW from New Brunswick to Nova Scotia (TSR-411), and one 500 MW long-term firm transmission service request from Newfoundland to Nova Scotia (TSR-412) that also must be accounted for. The two transmission service requests are expected to be in service in 2025 and system studies are currently underway to determine the associated upgrades to the Nova Scotia transmission system. These upgrades are expected to materially alter the configuration of the transmission system in Nova Scotia. As a result, the following notice has been posted to the OASIS site at <https://www.nspower.ca/oasis/generation-interconnection-procedures>:

*Effective January 19th, 2021, please be advised that the completion of advanced-stage Interconnection Studies under the Standard Generator Interconnection Procedures (GIP) may be delayed pending the outcome of the Transmission Service Request (TSR) 411 and 412 System Impact Studies, which are expected to identify significant changes to the NSPI transmission system. The expected completion date for these studies is December 31, 2021. Feasibility Studies initiated prior to the completion of these TSR System Impact Studies will be performed based on the current system configuration.*

This study assumes that the addition of generation from IR#626 will displace coal-fired generation in eastern Nova Scotia for NRIS.

The assessment of the POI on the 230kV line L-7003 indicated that thermal loading violations would occur on L-6515 due to IR#626. As an alternative to upgrading the affected transmission lines, it is proposed that modifications to the setting of Remedial Action Schemes (RAS) be applied to alleviate most of these overloads. The situation of the POI on L-7003 requires a new RAS to accommodate a double-circuit contingency near Trenton affecting L-7004 plus L-7003. This new Limited Impact RAS is subject to approval by NPCC.

No violations of voltage criteria were found for IR#626.

Since L-7003 is classified as Bulk Power System, interconnection with that line will require a three-breaker 230kV ring bus. This new substation will be classified as Bulk Power System under NPCC criteria and Bulk Electric System under NERC criteria.

Data provided by the IC indicates that IR#626 will be utilizing the E3-FT version of the Enercon E-160 EP5 5.56 MW wind turbines. Based on the provided impedances of the transformers and typical collector circuit impedances, IR#626 will not be able to meet the net power factor of +0.95 to -0.95 at the Interconnection Facility 230kV bus without supplemental reactive power supply.

The analysis demonstrated that approximately 10 Mvar of switched capacitors installed at the 34.5kV bus of the Interconnection Facility would meet this requirement, although the Enercon model E3-FTQ could also be considered. As specific details of the collector circuits become available, the adequacy of reactive power supply will be further investigated in the System Impact Study. It is noted that the proposed Enercon models do not meet the requirement to produce full Mvar capability down to zero MW output.

IR#626 was not found to adversely impact the short-circuit capabilities of existing circuit breakers. Although flicker coefficients were not provided for the proposed generator, voltage flicker is expected to be a concern for this project on its own. It is assumed that the project design meets NSPI requirements for low-voltage ride-through and voltage control. Harmonics must meet the Total Harmonics Distortion provisions of IEEE 519. The minimum short circuit level at the Interconnection Facility 230kV bus is 1104 MVA with all lines in service, and 687 MVA with L-7003 open between the POI and 3C-Port Hastings, which results in a minimum short-circuit ratio of 6.9.

As the POI for IR#626 is part of the Nova Scotia Bulk Power System, protection at 3C-Port Hastings and 67N-Onslow must comply with NPCC Directory 4 Bulk Power System Protection Criteria. The IR#626 Interconnection Customer substation at Glen Dhu II will also be classified as Bulk Power System, and therefore protection systems at that site needs to meet NPCC BPS criteria, and is also classified as part of the NERC Bulk Electric System (BES), subject to the applicable NERC Reliability Criteria. As IR#626 has dispersed generation totalling more than 75 MVA, each generator will be classified as a BES element.

The preliminary value for the unit loss factor is calculated as +7.8% at the POI at L-7003, net of any losses on the IC facilities up to the POI.

The preliminary non-binding cost estimate for interconnecting 100 MW to the POI on L-7003, including the cost of the three-breaker ring bus line connection and protection upgrades at each end of L-7003 plus a 4.2 km spur line from the POI to the Interconnection Facility (using right-of-way supplied by the IC) is \$12,488,300 under the assumption that the proposed modifications to the set-point of existing RAS and the new Limited Impact RAS is approved by NPCC. The cost estimate includes a contingency of 10%, and this estimate will be further refined in the System Impact Study and the Facility Study. In this estimate, \$9,075,000 of the amount represents Network Upgrade costs which are funded by the IC but are eligible for refund under the terms of the GIP. The remainder of the costs are fully funded by the Interconnection Customer.

If transmission upgrades, instead of the proposed Limited Impact RAS, are found to be necessary to address these thermal overloads, the cost of Network Upgrades would increase by an estimated \$8,250,000. Elimination of the double-circuit tower contingency at Trenton, as an alternative to the development of the proposed new RAS, is estimated to increase the Network Upgrade costs by approximately \$2,200,000. These Network Upgrades would be funded by the IC and are eligible for refund under the terms of the GIP.

The estimated time to construct the Transmission Provider's Interconnection Facilities is 18-24 months, and the Network Upgrades are estimated to be completed 24-36 months after receipt of funds and cleared right of way from the IC.

## Table of Contents

	Page
Executive Summary .....	ii
1 Introduction .....	1
2 Scope .....	3
3 Assumptions .....	4
4 Projects with Higher Queue Positions .....	6
5 Short-Circuit Duty / Short Circuit Ratio .....	7
6 Voltage Flicker and Harmonics .....	8
7 Load Flow Analysis .....	8
8 Reactive Power and Voltage Control .....	13
9 System Security / Bulk Power Analysis .....	15
10 Expected Facilities Required for Interconnection .....	16
11 NSPI Interconnection Facilities and Network Upgrades Cost Estimate .....	17
12 Loss Factor .....	18
13 Issues to be addressed in SIS .....	19

# 1 Introduction

The Interconnection Customer (IC) submitted an Interconnection Request for Network Resource Interconnection Service (NRIS) for a proposed 100 MW wind generation facility interconnected to the NSPI transmission system, with a Commercial Operation Date of 2024-01-01. The Point of Interconnection (POI) requested by the customer is the 230kV circuit L-7003, approximately 67.8 km from the 3C-Port Hastings substation.

The IC signed a Feasibility Study Agreement to study the connection of their proposed generating facility to the NSPI transmission system dated 2021-09-30, and this report is the result of that Study Agreement. This project is listed as Interconnection Request 626 in the NSPI Interconnection Request Queue and will be referred to as IR#626 throughout this report.

Figure 1 shows the proposed geographic location of IR#626 in relation to the NSPI transmission system.

Figure 1 IR#626 Glen Dhu II Site Location

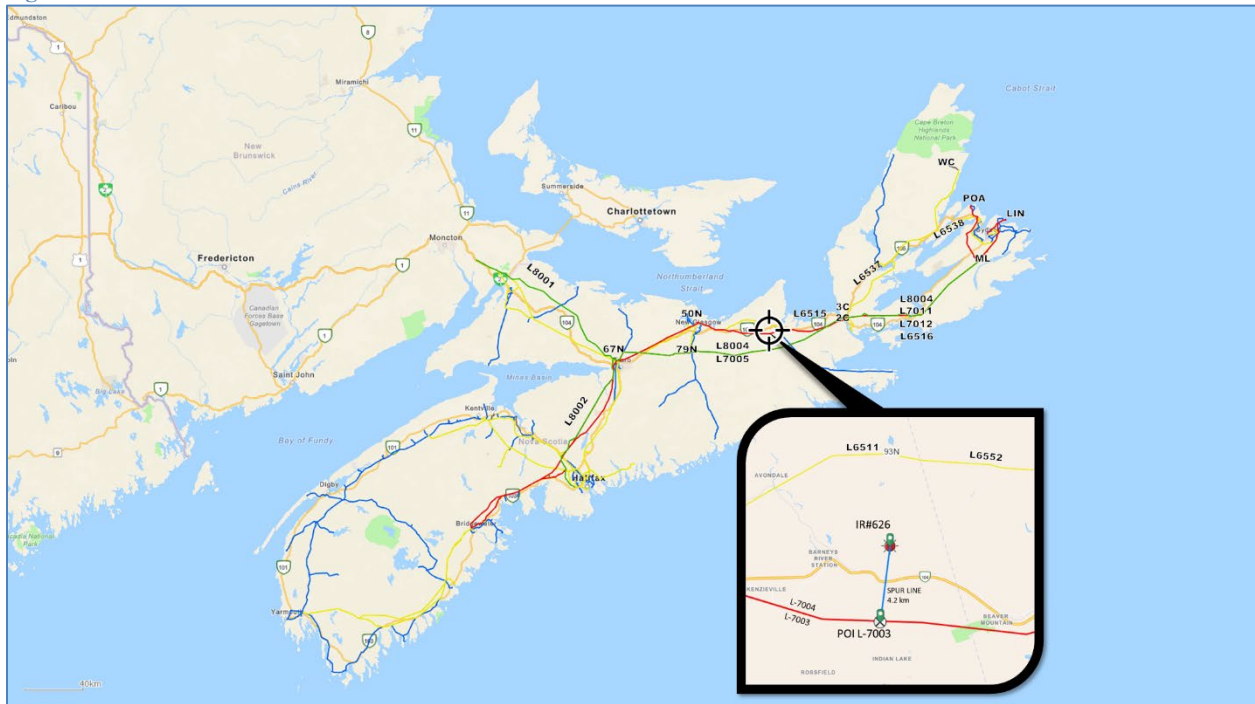

Figure 2 is a simplified one-line diagram of the transmission system configuration in central NS. Figure 3 shows the circuit breaker configuration of transmission lines in the vicinity of the POI.

# Control Centre Operations – Interconnection Feasibility Study Report

Figure 2 Point of Interconnection (not to scale)

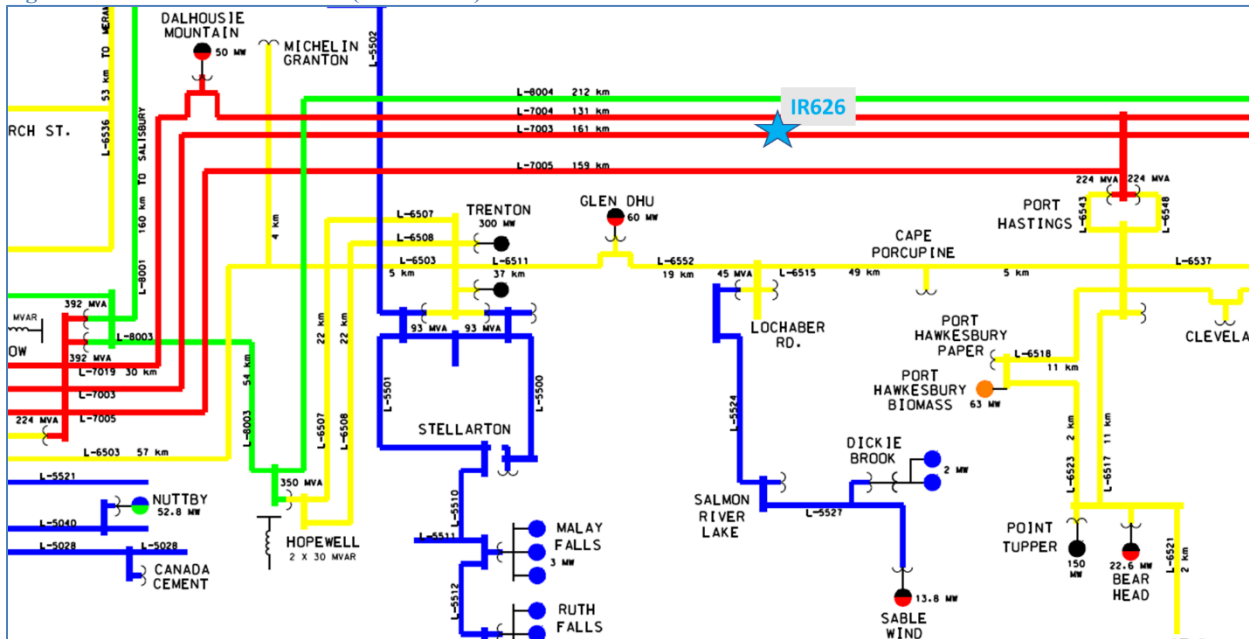
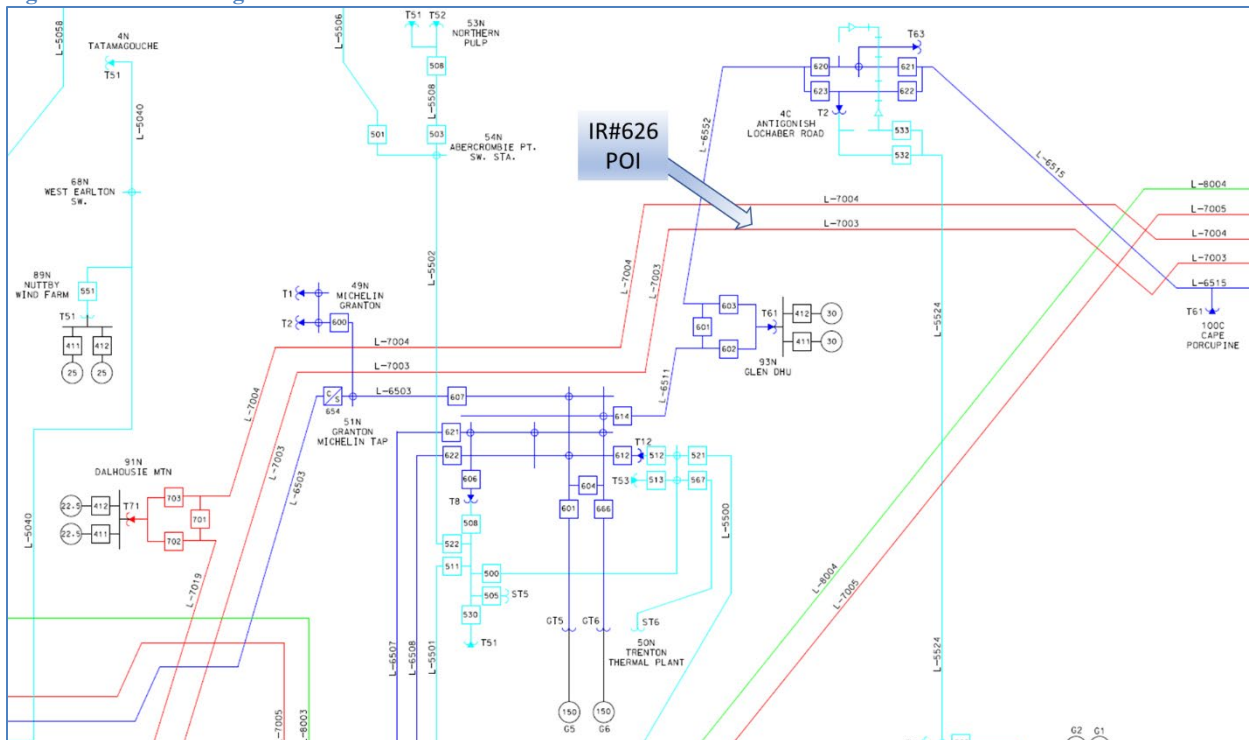

Figure 3 Circuit Configuration near POI



## 2 Scope

The objective of this Interconnection Feasibility Study (FEAS) is to provide a preliminary evaluation of system impacts from interconnecting the proposed generation facility to the NSPI transmission system at the requested location. The assessment will identify potential impacts on transmission element loading, which must remain within their thermal limits. Any potential violations of voltage criteria will be identified and addressed. If the proposed generation increases the short-circuit duty of any existing circuit breakers beyond their rated capacity, the circuit breakers must be upgraded. Single contingency criteria are applied.

The scope of the FEAS includes the modelling of the power system in normal state (with all transmission elements in service) under anticipated load and generation dispatch conditions. A power flow and short circuit analysis will be performed to provide the following information:

- Preliminary identification of any circuit breaker short circuit capability limits exceeded as a result of the interconnection, and any network upgrades necessary to address the short circuit issues associated with IR#626. Expected minimum short circuit capability will also be identified for the purposes of Short Circuit Ratio analysis.
- Preliminary identification of any thermal overload or voltage limit violations resulting from the interconnection and identification of the necessary network upgrades to allow full output of the proposed facility. Thermal limits are applied to the seasonal (summer/winter) emergency ratings of transmission elements. Voltage violations occur when the post-contingency transmission bus voltage is outside the range of +/-10% of nominal voltage.
- Preliminary analysis of the ability of the proposed Interconnection Facility to meet the reactive power, power quality and cold-weather capability requirements of the NSPI *Transmission System Interconnection Requirements*<sup>1</sup>.
- Preliminary description and high-level non-binding estimated cost and time to construct the facilities required to interconnect the generating facility to the transmission system.
- For comparative purposes, the impact of IR#626 on incremental system losses under standardized operating conditions is examined.

This FEAS is based on a power flow and short circuit analysis and does not include a complete determination of facility changes/additions required to increase the system transfer capabilities that may be required to meet the design and operating criteria established by NSPI, the Northeast Power Coordinating Council (NPCC), and the North

---

<sup>1</sup> [transmission-system-interconnection-requirements \(nspower.ca\)](http://transmission-system-interconnection-requirements (nspower.ca))

American Electric Reliability Corporation (NERC). These requirements will be determined by a more detailed analysis in the subsequent interconnection System Impact Study (SIS). An Interconnection Facilities Study (FAC) follows the SIS to ascertain the final cost estimate to the interconnect the generating facility.

### 3 Assumptions

This FEAS is based on the technical information provided by the Interconnection Customer. The Point of Interconnection (POI) and configuration is studied as follows:

1. NRIS per section 3.2 of the Generator Interconnection procedures (GIP).
2. Commercial Operation date 2024-01-01.
3. The Interconnection Customer Interconnection Facility (ICIF) consists of 19 Wind Energy Converter System (WECS) units; Enercon E-160 EP5 E3-FT 5.56 MW, 690V, Type 4 (full converter), capped at a total of 100 MW, connected to four feeder circuits operating at a voltage of 34.5kV.
4. The POI on L-7003 is considered Bulk Power System facilities and will therefore require three-breaker ring bus in accordance with Table 8 of the NSPI *Transmission System Interconnection Requirements*.
5. The ICIF is located approximately 4.2 km from the POI and will require the construction of a 230kV spur line. The IC will be responsible for providing the Right-of-Way for this spur line.
6. The generation technology used must meet NSPI requirements for reactive power capability of at least 0.95 capacitive to 0.95 inductive at the HV terminals of the IC substation step up transformer. It is also required to have high-speed Automatic Voltage Regulation to maintain constant voltage at the designated voltage control point during and following system disturbances as determined in the subsequent System Impact Study. The designated voltage control point will either be the low voltage terminals of the wind farm transformer, or if the high voltage terminals are used, equipped with droop compensation controls. It is assumed that the generating units are not de-rated in their MW capability when delivering the required reactive power to the system.
7. Preliminary data was provided by the IC for the IC substation interconnection facility transformer, consisting of one 230kV/34.5kV 75/100/125 MVA station transformer. The station transformer was modeled with a positive-sequence impedance of 10.0% on 75 MVA with an X/R ratio of 42. The IC indicated that this interconnection facility transformer has a grounded wye-delta-wye winding configuration with +/-10% on-load tap changer in (assumed) 32 steps. The impedance of each generator step-up transformer was not provided by the IC and is assumed as 9.9% on 6.2 MVA with an X/R ratio of 11.



## Control Centre Operations – Interconnection Feasibility Study Report

8. Detailed collector circuit data was not provided, so typical data ( $R+jX = 0.01+j0.04$  p.u. on system base 100 MVA) was assumed with the understanding that the net real and reactive power output of the plant will be impacted by losses through transformers and collector circuits.
9. The FEAS analysis is based on the assumption that IR's higher in the Generation Interconnection Queue and OATT Transmission Service Queue that have completed a System Impact Study, or that have a System Impact Study in progress will proceed, as listed in Section 4 below.
10. It is assumed that the wind turbines are equipped with a “cold weather option” suitable for delivering full power under expected Nova Scotia winter environmental conditions.
11. Planning criteria meeting NERC Standard TPL-001-4 *Transmission System Planning Performance Requirements* and NPCC Directory 1 *Design and Operation of the Bulk Power System* as approved for use in Nova Scotia by the Utility and Review Board, are used in evaluation of the impact of any facility on the Bulk Electric System.
12. L-7003 is a 230kV circuit between 3C-Port Hastings and 67N-Onslow EHV and is comprised of multiple sections with various conductors and structure designs as shown in Table 1. The POI for IR#626 is located on the line section between Trenton and Canso Causeway which uses 556.5 kcmil Dove ACSR with H-Frame wood pole structures. L-7003 is currently being uprated from an operating temperature of 60°C to 70°C. This study assumed that the upgrade is complete before IR#626 is in service.

Section	Length (km)	Conductor	Size	Type	Structure
67N-Onslow Entrance	0.83	Drake	795.0	ACSR	Gulfport
Onslow to Trenton	57.0	Dove	556.5	ACSR	H-Frame
50N Trenton bypass	1.45	Special C	626.7	ACSR	DC Steel
Trenton to IR#626 POI	29.6	Dove	556.5	ACSR	H-Frame
IR#626 POI to Canso Strait	64.9	Dove	556.5	ACSR	H-Frame
Canso Causeway	1.48	Special C	626.7	ACSR	DC Steel
Causeway to 3C-Port Hastings	1.37	Drake	795.0	ASCR	DC Steel

13. The ratings of transmission lines in the vicinity of IR#626 are shown in Table 2.

Line	Conductor	Design Temp	Limiting Element	Summer Rating Normal/Emergency	Winter Rating Normal/Emergency
L-6503	1113 Beaumont	85°C	Switchgear	287/315 MVA	287/315 MVA
L-6511	556.5 Dove	60°C	Conductor	140/154 MVA	184/202 MVA
L-6552	556.5 Dove	50°C	Conductor	110/121 MVA	143/157 MVA
L-6515	556.5 Dove	50°C	Conductor	110/121 MVA	143/157 MVA

<b>Table 2 Local Transmission Element Ratings</b>					
Line	Conductor	Design Temp	Limiting Element	Summer Rating Normal/Emergency	Winter Rating Normal/Emergency
L-7003	556.5 Dove	70°C	Conductor	273/303 MVA	345/379 MVA
L-7004	556.5 Dove	60°C	Conductor	233/246 MVA	307/338 MVA
L-7019	555.5 Dove	70°C	Conductor	273/303 MVA	345/379 MVA
L-7005	1113 Beaumont	70°C	CT Ratio	398/438 MVA	398/438 MVA

## 4 Projects with Higher Queue Positions

All in-service generation is included in the FEAS, except for Lingan Unit 2, which is assumed to be retired.

As of 2022-01-10, the following Transmission Interconnection projects are higher queued in the Advanced Stage Interconnection Request Queue and are committed to the study base cases:

- IR426: GIA executed
- IR516: GIA executed
- IR540: GIA executed
- IR542: GIA executed
- IR574: GIA in progress
- IR598: FAC in progress

The following projects have been submitted to the Transmission Service Request (TSR) Queue:

- TSR411: SIS in progress
- TSR412: SIS in progress

Preceding IR#626 are six transmission and three distribution Interconnection Requests with GIA’s executed. A long-term firm point-to-point transmission service reservation in the amount of 800 MW from New Brunswick to Nova Scotia (TSR-411) and a 500 MW long-term firm transmission service request from Newfoundland to Nova Scotia (TSR-412) are at the SIS stage. The two transmission service requests are expected to be in service in 2025 and system studies are currently underway to determine the required upgrades to the Nova Scotia transmission system. As a result, the following notice has been posted to the OASIS site at <https://www.nspower.ca/oasis/generation-interconnection-procedures>:

*Effective January 19th, 2021, please be advised that the completion of advanced-stage Interconnection Studies under the Standard Generator Interconnection Procedures (GIP) may be delayed pending the outcome of the Transmission Service Request (TSR) 411 and 412 System Impact Studies, which are expected to identify significant changes to the NSPI transmission system. The expected completion date for these studies is December 31, 2021. Feasibility Studies initiated prior to the*

*completion of these TSR System Impact Studies will be performed based on the current system configuration.*

## 5 Short-Circuit Duty / Short Circuit Ratio

The maximum expected (design) short-circuit level is 5,000 MVA (21 kA) on 138kV systems and 10,000 MVA (25 kA) on 230kV systems. The fault current characteristic for the Enercon Type 4 fully converted units is given as 1.08 times rated current, or  $X'd = 0.926$  per unit on machine base MVA.

Short circuit analysis was performed using PSS®E for a classical fault study, 3LG and flat voltage profile at 1.0 p.u. V. The short-circuit levels in the area before and after this development are provided below in Table 3.

<b>Table 3: Short-Circuit Levels. IR#626 (Type 4) on L-7003 Three-phase MVA <sup>(1)</sup></b>		
Location	Without IR#626	With IR#626
All transmission facilities in service		
POI on L-7003 (230kV)	1715	1799
Interconnection Facility (230kV)	1610	1693
3C-Port Hastings (230kV)	3117	3164
67N-Onslow (230kV)	4158	4204
Minimum Conditions (PA1, LG1, ML In-Service)		
Interconnection Facility (230kV), all lines in-service	1104	1188
Interconnection Facility (230kV), L-7003 open at 3C	687	771
Interconnection Facility (230kV), L-7003 open at 67N	876	835

(1) Classical fault study, flat voltage profile

The interrupting capability of the 230kV circuit breakers at 67N-Onslow and 3C-Port Hastings is at least 10,000 MVA. As such, the interrupting rating at these substations will not be exceeded by this development on its own.

Inverter-based generation installations often have a minimum Short Circuit Ratio (SCR) for proper operation of converters and control circuits. Based on the calculated short circuit levels, a POI on L-7003, and a 100 MW installation consisting of 19 units each 5.56 MW, the short circuit ratio would be 11.0 at the HV terminals of the IR#626 substation with all lines in service and IR#626 off line. This falls to 6.9 with L-7003 open at 3C-Port Hastings, and 7.5 if L-7003 is open at 67N-Onslow EHV.

## 6 Voltage Flicker and Harmonics

Flicker coefficient information was not provided for the Enercon E-160 – EP5 E3-FT / 5.560 MW Wind Turbines, however, it is known that Type 4 wind turbines typically have a flicker coefficient of 2.0 - 2.4 at angle of 85°, which is about half that of Type 3 machines. Type 4 wind turbines are not expected to result in appreciable voltage flicker at minimum generation conditions. Voltage flicker will be further examined when data for the 5.56 MW Enercon E-160 machine is made available for the SIS.

The generator is expected to meet IEEE Standard 519-2014 limiting voltage Total Harmonic Distortion (all frequencies) to a maximum of 1.5%, with no individual harmonic exceeding 1.5% on 230kV.

## 7 Load Flow Analysis

The load flow analysis was completed for generation dispatches under system summer peak load and winter peak load conditions which are expected to stress the east-west corridor across the transmission interfaces Cape Breton Export (CBX) and Onslow Import (ONI). Generation dispatch was also chosen to represent import and export scenarios that consider expected flows from the existing transmission service reservation associated with the Maritime Link, and scenarios where Maritime Link imports displace NS thermal generation.

The major transmission interfaces/corridors relating to the IR#626 are shown in Figure 4. The nominal interface limits are summarized in Table 4. NSPI relies on Remedial Action Schemes (RAS<sup>2</sup>) approved by NPCC to maintain interface limits. These RAS are armed by system conditions and flow across the respective interfaces and react to pre-determined contingencies to rapidly reduce flow by either tripping generation in Cape Breton or running-back Maritime Link HVdc import.

---

<sup>2</sup> Also referred to as Special Protection Scheme (SPS),

## Control Centre Operations – Interconnection Feasibility Study Report

Figure 4 Major Transmission Interfaces

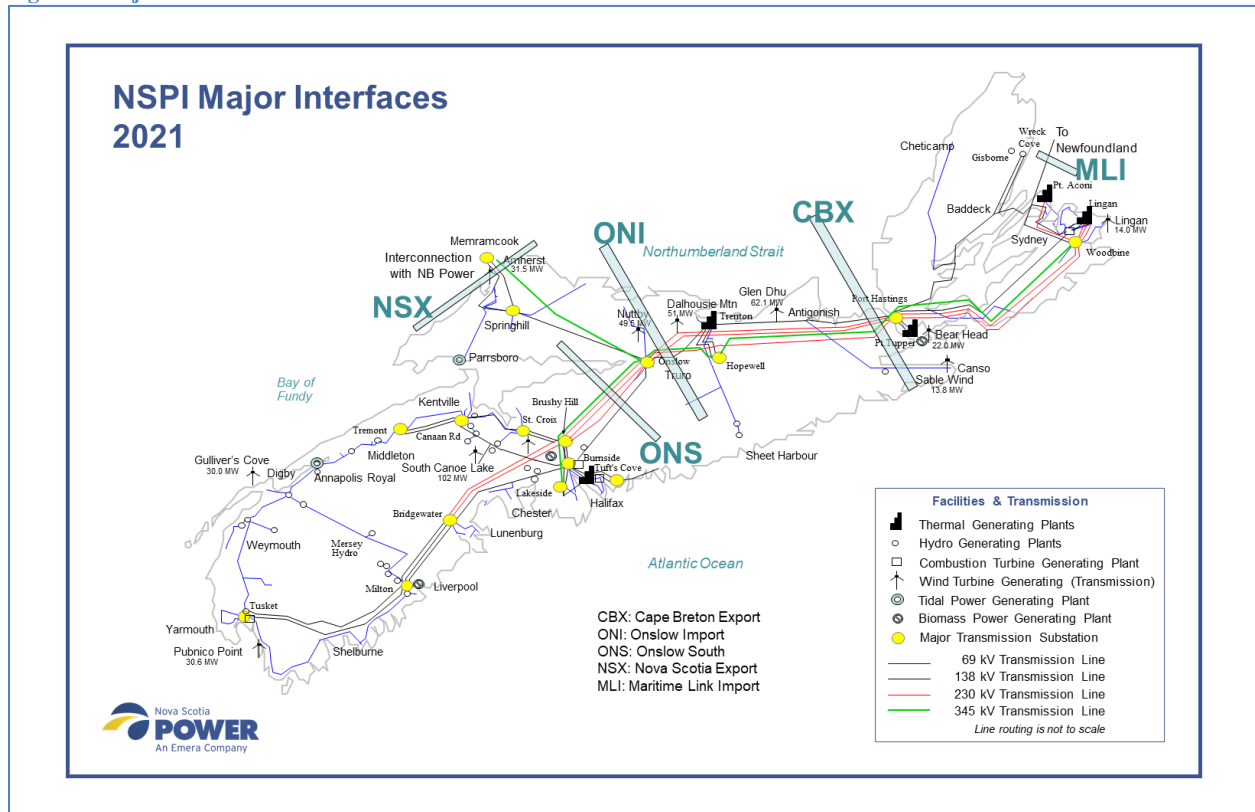

**Table 4 Transmission Interface Limits**

Interface	NLI (1)	NSX (2)	NSI (3)	CBX (4)	ONI	ONS (5)
Summer	475	500	Up to 300	875-1075	1075-1275	600-850
Winter	475	500	Up to 300	950-1150	1275	600-975

- (1) Newfoundland and Labrador Import (NLI) is limited by simultaneous New Brunswick Import
- (2) NS Export to NB (NSX) is dependant on Maritime Link runback RAS
- (3) NS import from NB (NSI) is dependant on conditions in NB and PEI, capped at 28% of NS load.
- (4) Dependant on generation at Trenton and Point Tupper
- (5) Dependant on reactive power reserve in Metro

Transmission connected wind generation facilities were typically dispatched at approximately 40%, except in the vicinity of IR#626. There is high co-relation between wind plants in the Central Region between Port Hastings and Onslow, so it is reasonable to expect that these other wind plants would be near full output when IR#626 is at rated output. The cases and dispatch scenarios considered are shown in Table 5.

## Control Centre Operations – Interconnection Feasibility Study Report

Table 5: Base Case Dispatch (MW) with IR#626 on-line									
Case	MLI	NS-NB	CBX	ONI	ONS	LIN	TRE	Wind	RAS (3)
SP01	475	333	881	980	580	202	78	310	79NG5
SP02	475	0	742	884	782	218	160	222	-
SP03	475	330	779	856	472	0 (1)	0	475	79NG5
SP04	475	0	650	885	820	220	165	350	-
SP05	475	170	976	1130	857	297	156 (2)	228	79NG5 67NG6
SP06	475	170	783	813	538	100	0	262	79NG5
SP07	-100	-250	67	308	462	120	160	367	-
WP01	320	150	845	1,165	870	380	324	333	67NG6
WP02	475	150	1050	1,210	920	380	165	318	79NG6 67NG6
WP03	320	150	753	1,064	792	384	324	335	67NG6
WP04	475	0	1,044	1,111	930	375	165	175	79NG5 67NG6
WP07	-100	-170	167	508	550	130	324	512	-
<b>S - Summer Peak    W - Winter Peak    LIN – Lingan Gen    TRE – Trenton Gen</b> (1) IR626 displaces 90 MW of Lingan plus 10 MW of Point Aconi (2) Two Trenton units at minimum load (3) Based on present RAS arming levels									

For NRIS analysis, this FEAS added IR#626 and displaced coal-fired generation in Cape Breton, reducing Cape Breton Export (CBX) transfers while maintaining Onslow Import (ONI) transfers. Single contingencies were applied at the 345kV, 230kV, and 138kV voltage levels for the above system conditions with IR#626 interconnected to the POI on L-7003. Automated analysis searched for violations of emergency thermal ratings and emergency voltage limits for each contingency. Contingencies studied are listed in Table 6.

Table 6 Contingency List			
Transmission Line	Transformer / Bus	Circuit Breaker Failure	Double Circuit Tower
L-7014, L-7021, L-7022	88S: T71, T72	88S: 710, 711, 713, 690, 721, 722, 723*	L-6534 + L-7021
L-7011, L-7012, L-7015, L-8004*	101S: T81, T82	101S: 701, 702, 703, 704, 705, 706, 711, 712, 713, 811, 812*, 813*, 814, 816	
L-6515, L-6516, L-6537*	2C: B61*, B62	4C: 620, 621, 622, 623	

## Control Centre Operations – Interconnection Feasibility Study Report

<b>Table 6 Contingency List</b>			
<b>Transmission Line</b>	<b>Transformer / Bus</b>	<b>Circuit Breaker Failure</b>	<b>Double Circuit Tower</b>
L-7003, L-7004, L-7005	3C-T71	3C: 710, 712, 713, 715, 716	L-7003+L-7004* Canso Causeway
L-6503, L-6613	1N: B61, B62	1N: 600, 613	
L-8001*, L-8002	67N: T71, T81	67N: 701, 702, 7-3, 705, 711, 712, 713, 811*, 812, 813, 814*, 815*	L-7003+L-7004 Trenton area
L-6507, L-6508, L-8003*	79N: T81*	79N: 601*, 606*, 803*, 810*	
Line segments either side of POI	91N: B71	91N: 701, 702, 703	

\*Indicates contingency was studied with/without RAS action

### Results

Several contingencies resulted in thermal overloads based on the current function and settings of RAS. In most cases, the overloads can be resolved by lowering the arming levels of these RAS without modification of the RAS design. This will increase the probability of a RAS operating and causing a run-back of the Maritime Link, or tripping of a thermal unit at Lingan or Point Aconi. Re-design of a RAS, or the addition of a new RAS, will be subject to the approval of NPCC.

No contingencies resulted in a violation of voltage limit criteria. Table 7 shows the highest thermal overloads found, but other conditions were found which also violated thermal loading criteria, but to a lesser degree.

<b>Table 7 Contingencies Resulting in Highest Line Overload</b>				
<b>Line</b>	<b>Line segment</b>	<b>Highest overload (% of Emergency Rating)</b>	<b>Case</b>	<b>Contingency</b>
L-6515	2C-Hastings / 4C-Lochaber Rd	Summer: 112%	SP05-2	101S-813 or L-8004
L-6515	2C-Hastings / 4C-Lochaber Rd	Summer: 108%	SP05-2	Trenton Double Circuit Tower

As shown in Figure 5 and outlined in Table 1, L-7003 has two locations where it shares a common tower with L-7004 (Canso Causeway and Trenton Bypass). NERC and NPCC considers simultaneous loss of two circuits on a multi-circuit tower to be a normal (single) contingency for which voltage, stability, and thermal loading criteria must be met. There is currently a RAS (Group 3) which will operate for loss of these two circuits if the faults are at either location. However, because IR#626 POI will split L-7003 between Port Hastings and the Trenton area the existing RAS will not function for the double-circuit contingency at the Trenton Bypass.

Figure 4 Flags show the location of double-circuit contingencies

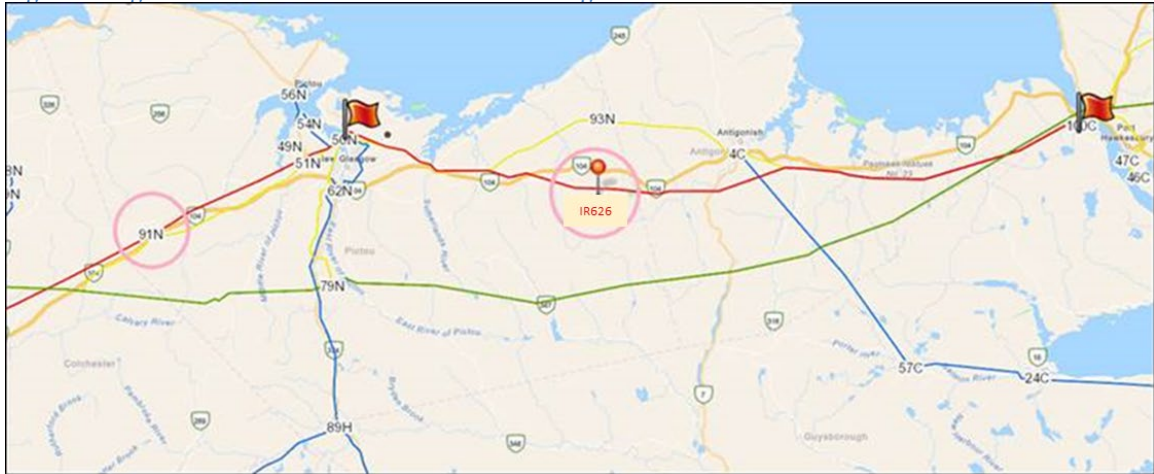

The following options were examined for the Trenton Bypass double-circuit contingency (classified as Network Upgrades, therefore funded by the IC by eligible for refund under the GIP:

1. Uprate L-6515 from 50°C to 60°C. This line uses a Dove 556.5 kcmil ACSR from 2C-Port Hastings to 4C-Lochaber Rd, a distance of 48 km (not including the Canso Causeway which has a larger conductor). This would increase its summer thermal rating by 27%, however switches at the 4C end would need to be replaced. The estimated cost is \$7,500,000.
2. Build a new single circuit line section to separate L-7004 from L-7003 at the Trenton Bypass. This would require a new right-of-way and would involve a 500m river crossing at Greens Point. It is estimated to cost at least \$2,000,000 (excluding river crossing structures).
3. Design and build a new RAS to detect the Trenton Bypass double-circuit contingency and run-back IR#626 plus Maritime Link. This is estimated to cost \$200,000 with the assumption that it will be approved by NPCC.

For the other contingencies resulting in thermal overload of L-6515 the options examined included:

1. Uprate L-6515 as above at a cost of \$7,500,000 (this would also eliminate the Trenton DCT issue as well as other contingencies that are not covered by the other options).
2. Reduce arming values for existing Group 3, Group 5 and Group 6 RAS, estimated at \$50,000 if no functional changes are required.

The recommended options are design of a new Limited Impact RAS for the Trenton Bypass DCT, and reduction of the arming level of existing RAS.



## 8 Reactive Power and Voltage Control

In accordance with the *Transmission System Interconnection Requirements* Section 7.6.2, IR#626 must be capable of delivering reactive power at a net power factor of at least +/- 0.95 of rated capacity to the high side of the plant interconnection transformer. Reactive power can be provided by the asynchronous generator or by continually acting auxiliary devices such as STATCOM, DSTATCOM or synchronous condenser, supplied by the Interconnection Customer.

Figure 6: Model E-FT WECS Reactive Capability

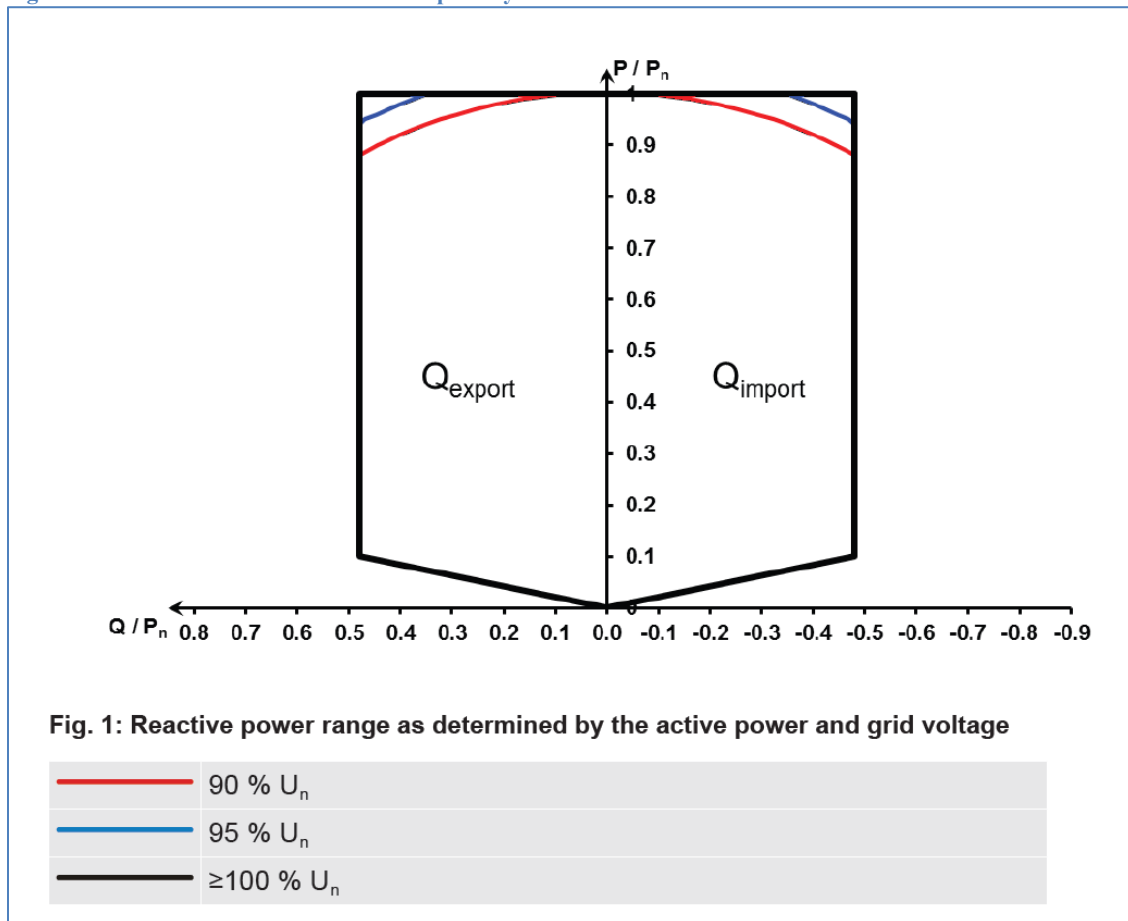

The information provided by Enercon (Figure 6) indicates that the Enercon E-160 EP5 E3-FT 5.56 MW WECS have a rated power factor of 0.9 lagging and leading (+/- 2.7 Mvar per WECS, total of 51 Mvar) at a machine terminal voltage of 1.0 p.u. or above, from 10% to 100% of rated power. However, the NSPI Transmission System Interconnection Requirements (Section 7.6.2) requires that rated reactive power shall be available through the full range of real power output of the Generating Facility, from zero to full power.

Analysis shown in Figure 7 indicates that IR#626 will not be able to meet the full-load reactive power requirement without additional reactive support. The model shows that with

19 WECS units (E3-FT version) operating at a total 100 MW and 51 Mvar at terminal voltage of 1.07 p.u., the delivered power to the high side of the interconnection transformer is 97.7 MW and 22.1 Mvar, or a power factor of 0.975. The model shows one alternative would be adding 10 Mvar of capacitors at the low voltage terminals of the ICIF would provide the required power factor on the 230kV bus. The use of Enercon model E3-FTQ could also be considered. This configuration would be able to meet the leading power factor requirement of -0.95 while the WECS are operating at 100 MW and -15.0 Mvar at a terminal voltage of 0.99 p.u.

Because this analysis is based on preliminary transformer data and assumed collector circuit models, reactive capability will be confirmed in the SIS.

A centralized controller will be required which continuously adjusts individual generator reactive power output within the plant capability limits and regulates the voltage at the 34.5kV bus voltage. The voltage controls must be responsive to voltage deviations at the terminals of the Interconnection Facility substation; be equipped with a voltage set-point control; and also have the ability to slowly adjust the set-point over several (5-10) minutes to maintain reactive power within the individual generators capabilities. The details of the specific control features, control strategy and settings will be reviewed and addressed in the SIS, as will the dynamic performance of the generator and its excitation. Line drop compensation, voltage droop, control of separate switched capacitor banks must be provided.

The NSPI System Operator must have manual and remote control of the voltage set-point and the reactive set-point of this facility to coordinate reactive power dispatch requirements.

This facility must also have low voltage ride-through capability as per Appendix G of the Standard Generator Interconnection and Operating Agreement (GIA). The SIS will state specific options, controls and additional facilities that are required to achieve this.

Settings for the ICIF on-load tap-changer must be coordinated with plant voltage controller for long-term reactive power and voltage management at the POI.

Figure 7: Power Factor Analysis

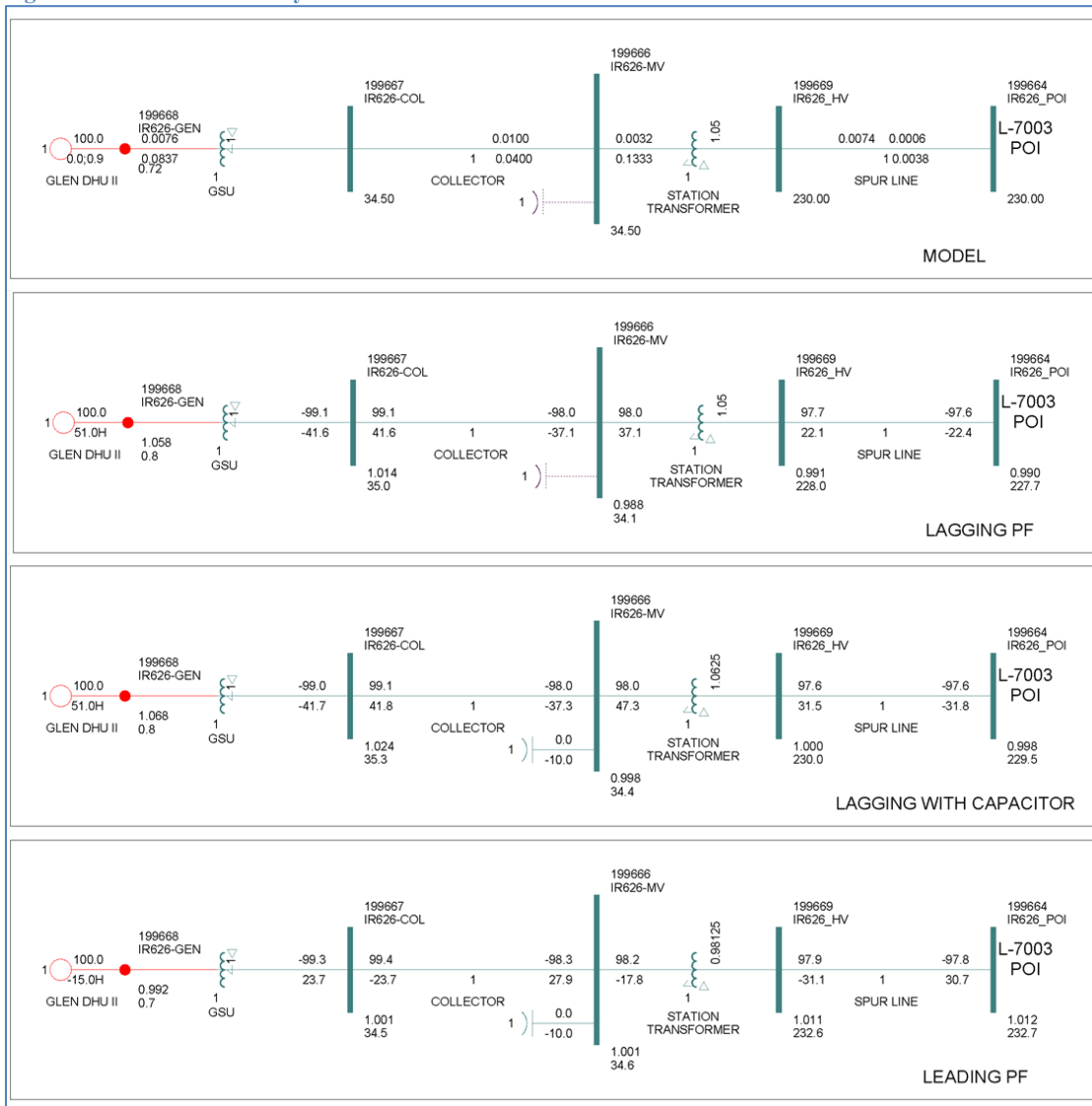

## 9 System Security / Bulk Power Analysis

The 230kV buses at the 67N-Onslow EHV substation and the 3C-Port Hastings substation as well as line L-7004 are part of the Nova Scotia Bulk Power System (BPS). As such, all protection systems associated with the new three-breaker ring bus at the POI must comply with NPCC Directory 4 *System Protection Criteria*.

Since the 67N-Onslow EHV and 3C-Port Hastings substations are currently classified as part of the NERC Bulk Electric System (BES), they are also subject to the applicable NERC Reliability Criteria. As IR#626 has dispersed generation totalling more than 75 MVA,

Inclusion I4 of the NERC BES Definition would apply, and each generator would be classified as a BES element. The IR#626 230kV bus would be classified as a BES element, including the 230kV – 34.5kV interconnection transformer and low voltage bus.

Line L-7003 presently has RAS installed (Group 3 and Group 4) which will be impacted by the installation of a Transmission Provider Interconnection Facility (TPIF) substation on this circuit. Modifications will be required to account for the fact that the TPIF would create two separate circuits. This RAS is classified as Type III, and the modifications may require approval by NPCC.

## 10 Expected Facilities Required for Interconnection

The following facility changes will be required to connect IR#626 to the NSPI transmission system at a POI on L-7003 under NRIS:

### a. Required Network Upgrades

- Modification of NSPI protection systems at 67N-Onslow EHV and 3C-Port Hastings.
- Install a new 230kV substation complete with 3 breaker ring bus at the POI at L-7003 with control and protection. A Remote Terminal Unit (RTU) to interface with NSPI's SCADA, with telemetry and controls as required by NSPI.
- Changes to the setpoint of existing NSPI RAS (Group 3, Group 5 and Group 6) plus a new Type III RAS for the Trenton Bypass double-circuit tower, with approval by NPCC.

### b. Required Transmission Provider's Interconnection Facilities (TPIF):

- Construct a 4.2 km spur line between the POI on L-7003 and the Interconnection Customer's Interconnection Facility. This line would be built to 230kV standards, with the IC responsible for providing Right-of-Way.
- Add control and communications between the wind farm and NSPI SCADA system (to be specified).

### c. Required Interconnection Customer's Interconnection Facilities (ICIF)

- Facilities to provide 0.95 leading and lagging power factor when delivering rated output at the HV terminals of the IC Substation Step Up Transformer when the voltage at that point is operating between 95 and 105 % of nominal. This study found that Enercon model E3-FT would not meet this requirement, and

supplemental reactive power such as a 10 Mvar capacitor bank would be needed. Additionally, the data provided did not meet the requirement that rated reactive power be delivered from zero to full rated real power.

- Centralized controls. These will provide centralized voltage set-point controls and are known as Farm Control Units (FCU). The FCU will control the 34.5kV bus voltage and the reactive output of the machines. Responsive (fast-acting) controls are required. The controls will also include a curtailment scheme which will limit or reduce total output from the facility, upon receipt of a telemetered signal from NSPI’s SCADA system.
- NSPI will have control and monitoring of reactive output of this facility, via the centralized controller. This will permit the NSPI Operator to raise or lower the voltage set-point remotely.
- Low voltage ride-through capability per Section 7.4.1 of the Nova Scotia Power Transmission System Interconnection Requirements (TSIR).
- Real-time monitoring (including an RTU) of the interconnection facilities. Local wind speed and direction, MW and Mvar, as well as bus voltages are required.
- Facilities for NSPI to execute high speed rejection of generation (transfer trip) if determined in SIS. The plant may be incorporated into RAS run-back schemes.
- Synthesized inertial response controls within the WECS.
- Automatic Generation Control to assist with tie-line regulation.
- Operation at ambient temperature of -30°C.

## **11 NSPI Interconnection Facilities and Network Upgrades Cost Estimate**

Estimates for NSPI Interconnections Facilities and Network Upgrades for interconnecting 100 MW wind energy at the 230kV POI at on L-7003 are included in Table 7.

<b>Table 7 Cost Estimate NRIS @ POI L-7003 with new Limited Impact RAS</b>		
<b>Item</b>	<b>Network Upgrades</b>	<b>Estimate</b>
1	Three breaker ring bus 230kV substation complete with P&C at NSPI POI substation and connection to L-7003, including P&C modifications at 3C-Port Hastings and 67N-Onslow EHV	\$8,000,000
2	Modifications to RAS settings Group 3, Group 5, Group 6	\$50,000
3	New Type III RAS for Trenton Bypass	\$200,000
	Sub-total for Network Upgrades	\$8,250,000

## Control Centre Operations – Interconnection Feasibility Study Report

Item	TPIF Upgrades	Estimate
1	Build 230kV spur line from TPIF to ICIF (4.2 km), with the IC providing right-of-way	\$2,793,000
2	NSPI P&C relaying equipment	\$100,000
3	NSPI supplied RTU	\$60,000
4	Tele-protection and SCADA communications	\$150,000
	Sub-total for TPIF Upgrades	\$3,103,000
	<b>Total Upgrades</b>	<b>Estimate</b>
	Network Upgrades + TPIF Upgrades	\$11,353,000
	Contingency (10%)	\$1,135,300
	Total (Incl. 10% contingency and Excl. HST)	\$12,488,300

The preliminary non-binding cost estimate for interconnecting 100 MW at the POI at L-7003 under NRIS is \$12,488,300 including a contingency of 10%. In this estimate, \$8,250,000 (plus 10% contingency) represents Network Upgrade costs which are funded by the Interconnection Customer, but which are eligible for refund under the terms of the GIP. This does not include TBD costs to address any stability issues identified at the SIS stage based on dynamic analysis, and it assumes that RAS addition is approved by NPCC.

The estimated time to construct the Transmission Provider’s Interconnection Facilities is 18-24 months after receipt of funds and cleared right of way from the IC.

The estimated time to construct the Network Upgrades is 24-36 months after receipt of funds from the IC. This includes the time to seek approval of the new Limited Impact RAS from NPCC.

## 12 Loss Factor

Loss factor is calculated by running the winter peak load flow case with and without the new facility in service while keeping 91H-Tufts Cove as the Nova Scotia Area Interchange bus. This methodology reflects the load centre in and around Metro.

Without IR#626 in service, losses in the winter peak case total 86.2 MW. With IR#626 in service at the POI of L-7003, displacing generation at 91H, and not including losses associated with the IR#626 Generation Facilities or TPIF Interconnection Facilities, system losses total 93.79 MW, an increase of 7.59 MW. The model shows power delivered to the POI is 97.6 MW, therefore the loss factor is calculated as  $7.59/97.6 = +7.8\%$ .

## 13 Issues to be addressed in SIS

The following provides a preliminary scope of work for the subsequent SIS for IR#626. The SIS will include a more comprehensive assessment of the technical issues and requirements to interconnect generation as requested. It will include contingency analysis, system stability, ride through, and operation following a contingency (N-1 operation). The SIS must determine the facilities required to operate this facility at full capacity, withstand any contingencies (as defined by the criteria appropriate to the location) and identify any restrictions that must be placed on the system following a first contingency loss. The SIS will confirm the options and ancillary equipment that the customer must install to control flicker, voltage, frequency response, active power and ensure that the facility has the required ride-through capability. The SIS will be conducted in accordance with the GIP with the assumption that all appropriate higher-queued projects proceed, and the facilities associated with those projects are installed.

The following outline provides the minimum scope that must be complete in order to assess the impacts. It is recognized the actual scope may deviate, to achieve the primary objectives.

The assessment will consider but not be limited to the following.

- i. Facilities that the customer must install to meet the requirements of the GIP and the *Transmission System Interconnection Requirements*.
- ii. The minimum transmission additions/upgrades that are necessary to permit operation of this Generating Facility, under all dispatch conditions, catering to the first contingencies listed.
- iii. Guidelines and restrictions applicable to first contingency operation (curtailments etc.).
- iv. Under-frequency load shedding impacts.

To complete this assessment the following first contingencies, as a minimum, will be assessed:

- L-8001
- L-8004
- L-8003
- Transformer 79N-T81
- L-7003 either side of IR#626
- L-7019 with 91N generation
- L-8004 & 79N-T81 (common circuit breaker)
- L-8004 & 101S-T81 (common circuit breaker)
- 1N-B61 (bus fault)
- L-7004 & 3C-T71 (common circuit breaker)

## Control Centre Operations – Interconnection Feasibility Study Report

---

- L-7004 & L-7012 (common circuit breaker)
- L-7005
- Loss L-7003 & L-7004 (double circuit tower) at Canso Causeway and Trenton Bypass
- Loss of largest generation source in NS
- Loss of Maritime Link

To complete this assessment the dynamics of the following first contingencies, as a minimum, will be assessed:

- 3 phase fault L-8004 at 101S-Woodbine, CBX and ONI, RAS armed
- 3 phase fault L-8003 at 67N-Onslow, ONI RAS armed
- 3 phase fault L-8001 with high NS import from NB (islanding)
- 3 phase fault L-8002 at 67N-Onslow
- Simultaneous SLG on L-7003 and L-7004 double circuit tower at 3C-Port Hastings
- SLG L-8003 at Onslow, drops 67N-T82, 345kV RAS Operation
- 3 phase fault at 79N-Hopewell, drops L-8003, 8004, bus, RAS operation
- 3 phase fault 1N-Onslow 138kV bus B61

Any changes to RAS schemes required for operation of this generating facility, in addition to existing generation and facilities that can proceed before this project, will be determined by the RAS as well as any required additional transmission facilities. The determination will be based on NERC<sup>3</sup> and NPCC<sup>4</sup> criteria as well as NSPI guidelines and good utility practice. The SIS will also determine the contingencies for which this facility must be curtailed.

---

Nova Scotia Power  
Transmission System Operations  
2022-01-14

---

<sup>3</sup> NPCC criteria are set forth in its Reliability Reference Directory #1 *Design and Operation of the Bulk Power System*

<sup>4</sup> NERC transmission criteria are set forth in *NERC Reliability Standard TPL-001-4*