

Interconnection Feasibility Study Report

GIP-364-FEAS-R1

System Interconnection Request #364

50 MW Wind Generating Facility

Colchester County (L-6513)

2012-02-28
Control Centre Operations
Nova Scotia Power Inc.

Executive Summary

The IC submitted an Interconnection Request (IR#364) for Network Resource Interconnection Service (NRIS) to NSPI for a proposed 50 MW wind generation facility interconnected to the NSPI transmission system, and also asked that Energy Resource Interconnection Service (ERIS) be studied concurrently. The Point of Interconnection (POI) requested by the customer is on L-6513 between 74N-Springhill and 81N-Debert substations via approximate 8 km of newly-constructed line from the wind farm, and the POI is located approximately 15 km away from the 81N-Debert end. An alternative POI on 345 kV line L-8001 was also identified. However the L-8001 POI was not pursued in this study due to significant network upgrade costs.

In addition to the proposed generating facility, a Transmission Service Request (TSR-100) and two Interconnection Requests (IR#225 and IR#234) are higher queued and will have an impact on the projects in northern Nova Scotia. TSR-100 has an in-service date of 2016 and both IR#225 and IR#234 have an in-service date of 2017, whereas IR#364 has an in-service date of 2014. Therefore the FEAS for this IR is performed twice – for 2014 without TSR-100, IR#225 and IR#234 in service and again for 2017 with them in-service.

Under the pre-existing “Import Power Monitor” SPS arming level (without TSR-100) when L-8001 trips for any reason, the flow on L-6513 could be at its conductor thermal limit during periods when summer line ratings are in effect. With the addition of IR#364, loss of L-8001 could cause L-6513 to be overloaded up to 160% of its thermal rating during periods when summer line ratings are in effect. Similarly, thermal violations on L-6513 could also occur under the contingency of breaker failure of 88S-721 with high NS imports (up to 300 MW) during periods when summer line ratings are in effect. For NS export (up to 350 MW) when both Trenton units are online with summer line ratings, the addition of IR#364 could cause L-6513 between IR#364 and 74N-Springhill to be overloaded up to 117% of its conductor thermal ratings under a bus fault on 1N-B61. The overload violations would be worse when two higher Queued projects (IR#225 and IR#234) are in-service in 2017 in spite of the related system upgrades. The overload violations could still occur with both Trenton units generating at minimum output. To accommodate IR#364 as NRIS L-6513 would be required to be up-rated or to be completely re-built. The cost of L-6513 reinforcement will depend on the number of structures and spans that need to be remedied, but an estimate of the cost ranges from \$8.2M for thermal uprating to \$19.2M for complete rebuild. This study assumes that L-6513 can be up-rated for associated cost estimates.

The “Import Power Monitor” SPS will no longer be used under normal system conditions once the system upgrades associated with TSR-100 are completed in 2016. IR#364 can therefore operate without restrictions assuming that L-6513 is up-rated in 2014.

As ERIS with no major transmission reinforcement on L-6513 IR#364 would require the establishment of significant operating restrictions while:

- NS imports 30-100MW before TSR-100 is in service,
- High NS import (up to 300 MW before TSR-100 & up to 720 MW after TSR-100 is in-service),
- High NS export with both Trenton generators online.

The restrictions also depend on other local generation real-time output and load demands besides NS Import/Export level. The operating restrictions on IR#364 while NS imports 30-100 MW would be eliminated after TSR-100 is in service. The operating restrictions during summer with high NS import (up to 300 MW) would be eliminated after TSR-100 is in service; however there would also be operating restrictions required while NS imports above 540MW after TSR-100 is in-service in 2016 due to the thermal overloads on L-6513 under either the loss of 345 kV line from New Brunswick or the breaker failure of 88S-721, otherwise NS import has to be reduced. The operating restrictions while NS exports would become significant when IR#225 and IR#234 are in service in 2017 (in spite of the system changes required by these projects), and they will be required with or without TSR-100. Otherwise the overload violations could still occur with both Trenton units generating at minimum output. Instead of the operating restrictions the potential thermal overloads could also be managed by a new Special Protection System (SPS) by tripping the wind farm coincident with a bus fault on 1N-B61. However, the new SPS scheme would have to be presented to NPCC and would require their approval.

No concern regarding short-circuit was found for this project on its own. Available flicker coefficient data for this type of machine indicates that voltage flicker will not be a problem. The project design must meet NSPI requirements for low-voltage ride-through, reactive power range and voltage control system. Based on the provided power factor of the Vestas V100-2.0 MW (0.95), and the provided impedances of the transformers, supplementary reactive support may be needed in the form of capacitor banks at the low voltage terminals of the Interconnection Transformer. This will be further investigated in the System Impact Study. Harmonics must meet the Total Harmonics Distortion provisions of IEEE 519.

The preliminary value for the unit loss factor is calculated to be 4.2% (system losses increased by net 2.1 MW when IR #364 is operated at 50 MW).

The preliminary non-binding cost estimate for interconnecting 50 MW onto L-6513 would be \$18.7M for NRIS and \$9.3M for ERIS with operating restrictions. Both cost estimates include a contingency of 10%. These estimates will be further refined in the System Impact Study and the Facility Study.

Table of Contents

	Page
Executive Summary	ii
1 Introduction	1
2 Scope	1
3 Assumptions	2
4 Projects with Higher Queue Positions	3
5 Objective	4
6 Short-Circuit Duty	5
7 Voltage Flicker and Harmonics	5
8 Thermal Limits.....	6
9 Voltage Limits	8
10 System Security /Bulk Power Analysis	9
11 Expected Facilities Required for Interconnection	10
12 NSPI Interconnection Facilities and Network Upgrades Cost Estimate	11
13 Issues to be addressed in SIS.....	12

1 Introduction

The IC submitted an Interconnection Request (IR#364) for Network Resource Interconnection Service (NRIS) to NSPI for a proposed 50 MW wind generation facility interconnected to the NSPI transmission system, and also asked that Energy Resource Interconnection Service (ERIS) be studied concurrently. The Point of Interconnection (POI) requested by the customer is on L-6513 between 74N-Springhill and 81N-Debert substations via approximate 8 km of newly-constructed line from the wind farm. An alternative POI on line L-8001 was also identified by the IC. Both of the POIs are located approximately 28 km away from the 67N/1N-Onslow substation. However the L-8001 POI was not pursued in this study due to significant network upgrade costs.

The Interconnection Customer (IC) signed a Feasibility Study Agreement to study the connection of their proposed generating facility to the NSPI transmission system dated 2011-12-08, and this report is the result of that Study Agreement. This project is listed as Interconnection Request #364 in the NSPI Interconnection Request Queue, and will be referred to as IR#364 throughout this report.

2 Scope

This Interconnection Feasibility Study (FEAS) consists of a power flow and short circuit analysis. Based on this scope, the FEAS report shall provide the following information:

1. Preliminary identification of any circuit breaker short circuit capability limits exceeded as a result of the interconnection;
2. Preliminary identification of any thermal overload or voltage limits violations resulting from the interconnection;
3. Preliminary description and high level non-bonding estimated cost of facilities required to interconnect the Generating Facility to the Transmission System and to address the identified short circuit and power flow issues.

The Scope of this FEAS includes modeling the power system in normal state (with all transmission elements in service) under anticipated load and generation dispatch conditions.

In accordance with Section 3.2.1.2 of Standard Generation Interconnection Procedures (GIP), as approved by the UARB on February 10, 2010, the FEAS for ERIS consists of short circuit/fault duty, steady state (thermal and voltage) analyses. The short circuit/fault duty analysis would identify direct Interconnection Facilities required and the Network Upgrades necessary to address short circuit issues associated with the Interconnection Facilities. The steady state studies would identify necessary upgrades to allow full output of the proposed Generating Facility and would also identify the maximum allowed output, at the time the study is performed, of the interconnecting Generating Facility without requiring additional Network Upgrades. It is therefore assumed that transmission interfaces limits will not be exceeded to avoid system upgrades in an ERIS study.

In accordance with Section 3.2.2.2 of the GIP, the Interconnection Study for NR Interconnection Service shall assure that the Interconnection Customer's Generating Facility meets the requirements for NR Interconnection Service and as a general matter, that such Generating Facility's interconnection is also studied with the Transmission Provider's Transmission System at peak load, under a variety of severely stressed conditions, to determine whether, with the Generating Facility at full output, the aggregate of generation in the local area can be delivered to the aggregate of load on the Transmission Provider's Transmission System, consistent with the Transmission Provider's reliability criteria and procedures.

A more detailed analysis of the technical implications of this development will be included in the System Impact Study (SIS) report. The SIS includes system stability analysis, power flow analysis such as single contingencies (including contingencies with more than one common element), off-nominal frequency operation, off-nominal voltage operation, low voltage ride through, harmonic current distortion, harmonic voltage distortion, system protection, special protection systems (SPS), automatic generation control (AGC) and islanded operation. The impacts on neighbouring power systems and the requirements set by reliability authorities such as Northeast Power Coordinating Council (NPCC), North American Electric Reliability Corporation (NERC), and NSPI will be addressed at that time and will include an assessment of the status of the Interconnection Facility as a Bulk Power System element. The SIS may identify and provide a non-binding estimate of any additional interconnection facilities and/or network upgrades that were not identified in this FEAS.

An Interconnection Facilities Study follows the SIS in order to ascertain the final cost estimate to interconnect the generating facility.

3 Assumptions

This FEAS is based on the technical information provided by the Interconnection Customer. The Point of Interconnection (POI) and configuration is studied as follows:

1. Network Resource Interconnection Service and Energy Resource Interconnection Service types per section 3.2 of the RGIP.
2. 50 MW wind with 25 2MW Vestas V100 Wind Turbines.
3. The generation technology used must meet NSPI requirement for reactive power capability of 0.95 capacitive to 0.95 inductive at the HV terminals of the IC Substation Step Up transformer. It is also required to have high-speed Automatic Voltage Regulation to maintain constant voltage at the generator terminals during and following system disturbances as determined in the subsequent System Impact Study.
4. The IC indicated that the generation interconnection point is on the line L-6513 between 74N-Springhill and 81N-Debert substations, approximately 15 km from 81N-Debert substation. The line tap to the wind facility is approximately 8 km.

5. Preliminary data was provided by the IC for the generator step-up and IC substation step-up transformers. Modeling was conducted with a 138kV-34.5kV 36/60 MVA Interconnection Facility transformer with a positive sequence impedance of 9% and an X/R ratio of 45. The IC indicated that this Interconnection Facility step-up transformer has a grounded wye-delta-wye winding configuration with +/-10% off-load tap changer. The impedance of generator step-up transformers is assumed to be 8% on 2.3 MVA.
6. The FEAS analysis is based on the assumption that IR's higher in the Generation Interconnection Queue and OATT Transmission Service Queue that have completed a System Impact Study, or that have a System Impact Study in progress will proceed, as listed in Section 4 below.

4 Projects with Higher Queue Positions

All in-service generation is included in the FEAS.

As of 2012-01-12 the following projects are higher queued in the Interconnection Request Queue and OATT Transmission Service Queue, and have the status indicated.

Interconnection Requests -Included in FEAS

- IR #8 GIA Executed
- IR #45 GIA Executed
- IR #56 GIA Executed
- IR #151 GIA Executed
- IR #219 GIA Executed
- IR #227 GIA in Progress
- IR #225 GIA in Progress
- IR #234 SIS completed

Interconnection Requests –Not Included in FEAS

- IR #131 SIS Milestones Met
- IR #360 SIS in progress
- IR #362 SIS in progress

OATT Transmission Service Queue– Included in FEAS

- TSR-100 SIS in progress

OATT Transmission Service Queue– Not Included in FEAS

- TSR-400 SIS Agreement Completed

While TSR-100, IR#225 and IR#234 are higher queued, TSR-100 has an in-service date of 2016 and both IR#225 and IR#234 have an in-service date of 2017; whereas IR#364 has an in-service date of late 2014. Therefore the FEAS for this IR will be performed

twice – for 2014 without TSR-100, IR#225 and IR234 in service and again for 2017 onwards with them in-service, along with any related system changes.

The additional Transmission Service Request TSR-400 and Interconnection Requests IR#131, IR#360 and IR#362 are higher queued than IR#364 and SISs are either in progress or about to be initiated. However, the results of these SISs are not sufficiently defined to be included in the FEAS for IR#364.

The following IRs either have SIS Agreements complete (but have not yet met the RGIP SIS progression milestones), or have Feasibility Study agreements complete. As such, they are not included in this FEAS.

IR #67	IR #68	IR#117	IR #126	IR #128	IR #149
IR #163	IR #213	IR #222	IR #235	IR #238	IR #241
IR #242	IR #314	IR #356	IR#361		

If any of the higher-queued projects included in this FEAS are subsequently withdrawn from the Queue, the results of this FEAS may require updating or a re-study may be necessary. The re-study cost incurred as a result of the withdrawal of the higher-queued project shall be the responsibility of the Interconnection Customer that withdraws the higher queued project.

5 Objective

The objective of this FEAS is to provide a preliminary evaluation of the system impact and the high-level non-binding cost estimate of interconnecting the 50 MW generating facility to the NSPI transmission system at the designated location. The assessment will identify potential impacts on the loading of transmission elements, which must remain within their thermal limits. Any potential violations of voltage criteria will be identified and addressed. If the proposed new generation increases the short-circuit duty of any circuit breakers beyond their rated capacity, the circuit breakers must be upgraded. Single contingency criteria¹ are applied for both NRIS and ERIS assessments.

This FEAS is based on a power flow and short circuit analysis and does not include a complete determination of facility changes/additions required to increase system transfer capabilities that may be required to the Bulk Power System to meet the design and operating criteria established by NPCC and NERC or required to maintain system stability. These requirements will be determined by the subsequent interconnection System Impact Study (SIS).

¹ The Single Contingency Criteria is defined by NPCC in its A-7 Document, and may involve more than one transmission element.

6 Short-Circuit Duty

The maximum (design) expected short-circuit level is 5000 MVA on 138kV systems and 3500 MVA on 69 kV systems. The short-circuit levels in the area before and after this development (including TSR-100) are provided below in Table 6-1.

Table 6-1: Short-Circuit Levels. Three-phase MVA ⁽¹⁾		
Location	IR #364 in service	IR #364 not in service
All transmission facilities in service		
Interconnection Point (138 kV)	1300	1221
74N-Springhill 138 kV	1233	1217
1N-Onslow 138 kV	2374	2329
1N-Onslow 69 kV	633	632
Minimum Conditions		
Interconnection Point (138 kV)	903	825

⁽¹⁾ Classical fault study, flat voltage profile

In determining the maximum short-circuit levels with this generating facility in service the generators have been modeled as conventional machines with reactance comparable to induction machines regardless of the type of generators proposed, which provides a worst case scenario. The SIS will refine the fault level based on the actual machine characteristics.

The maximum short-circuit level at the POI on the 138 kV line L-6513 will be 1221 MVA in 2016. With IR # 364 the increase will bring the short-circuit level to 1300 MVA at the POI. Similarly, under summer light load conditions with certain generation units offline and certain lines out-of-service, the minimum short-circuit level will be approximately 825 MVA at the POI. This translates into maximum equivalent system impedance at the POI of 0.121 per unit on 100 MVA base.

The interrupting capability of the 138kV circuit breakers at 1N-Onslow is at least 3500 MVA, and the interrupting capability of the 138kV circuit breakers at 74N-Springhill is at least 5000 MVA and all 69 kV circuit breakers at that substation are rated at least 3500 MVA. As such, the interrupting ratings will not be exceeded by this development on its own. Therefore IR#364 will not impact the circuit breakers at these stations.

7 Voltage Flicker and Harmonics

Due to the lack of flicker coefficient information on the Vestas V100-2.0 MW machine, this study assumes typical flicker data for a Double-fed Induction Generator machine. The calculated voltage flicker at the POI using IEC Standard 61400-21 and the assumed values for typical DFIG machines is 0.044 under normal conditions and 0.065 under minimum

generation conditions. These are both below NSPI’s required limit of 0.35 for P_{st} . Therefore voltage flicker should not be a concern for this project.

The generator is expected to meet IEEE Standard 519 limiting Total Harmonic Distortion (all frequencies) to a maximum of 5%, with no individual harmonic exceeding 1%.

8 Thermal Limits

This facility is proposed to be interconnected onto L-6513 by constructing an approximately 8 km of 138kV transmission line with 795 ACSR Drake conductors and a conductor thermal rating of 220 MVA. The proposed new line terminal will be connected onto L-6513 via a three breaker ring-bus arrangement.

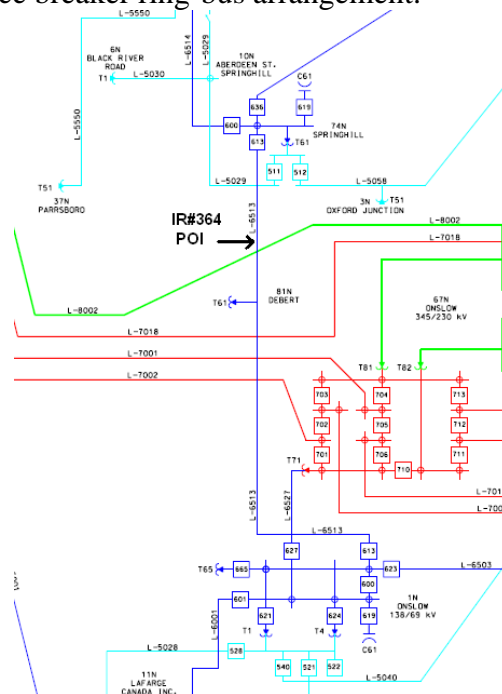

There are a number of Special Protection Systems employed by NSPI and NBSO to permit high transfer levels between Nova Scotia and New Brunswick. NSPI has an “Import Power Monitor” that acts to separate the two systems following the loss of the 345 kV tie (L-8001/L-3012) or lines in NB (L-3004, L-3006), by cross-tripping L-6513, to avoid the thermal violation on L-6513. Once this SPS operates, the load and generation in northern Nova Scotia are disconnected from the Nova Scotia system (but remain connected to New Brunswick). The Nova Scotia system is then islanded and relies on under frequency load shedding (UFLS) schemes to shed load across Nova Scotia to make up the generation deficiency and restore balance. Any new generating facilities added to the system in northern Nova Scotia (between Truro and New Brunswick) could have an impact on the transfer capability between Nova Scotia and New Brunswick and on the associated SPSs. The NSPI transmission line ratings records show that L-6513 between 74N-Springhill and 1N-Onslow substation is built with 556 ACSR Dove conductors with

a maximum operating temperature of 50°C and a Summer/Winter line rating of 110/165 MVA limited by conductor sag with the restriction of 172 MVA due to the metering at both line terminals and the protection at 1N-Onslow end. Under the pre-existing “Import Power Monitor” SPS arming level, the flow on L-6513 could be at its conductor thermal limit under summer line ratings when 345 kV line L-8001 trips for any reason. With the addition of IR#364 loss of L-8001 could cause L-6513 to be overloaded up to 160% of its conductor thermal ratings during periods when summer line ratings are in effect, assuming other generation in this area is concurrently generating at full output. The overloads would also depend on the real-time local load demands and other local generation output.

Thermal violations on L-6513 could also occur under the contingency of 88S-721 breaker failure (resulting in the loss of two generator units at 88S-Lingan) with high NS imports (up to 300 MW) during periods when the summer line ratings are in effect.

For high NS export levels (up to 350 MW) with both Trenton generators online during periods when summer line ratings are in effect, the addition of IR#364 could cause L-6513 to be overloaded up to 117% of its conductor thermal ratings under a bus fault on 1N-B61. The overload violations would be worse when two higher Queued projects (IR#225 and IR#234) are in service in 2017 in spite of the related system upgrades. The overload violations could still occur even with both Trenton units generating at minimum output.

Therefore L-6513 has to be either up-rated or completely re-built and some terminal equipment associated with L-6513 has to be upgraded to accommodate IR#364 as NRIS. The cost of L-6513 reinforcement will depend on the number of structures and spans that need to be remedied, but an estimate of the cost ranges from \$8.2M for thermal uprating to \$19.2M for complete rebuild. Further analysis will be required for the upgrade solutions of L-6513. This study assumes that L-6513 can be up-rated for IR#364 and the associated cost estimates are listed in Section 12.

TSR-100 involves a request for a NS import from New Brunswick of 320 MW (firm) plus 400 MW (non-firm) with an in-service date of 2016. System network upgrades associated with TSR-100 include:

- New 345 kV transmission line from Coleson Cove, NB to Salisbury, NB
- New 345 kV transmission line from Salisbury NB to Memramcook, NB
- New 345 kV transmission line from Memramcook, NB to Onslow NS
- Switched capacitor banks in NB at Memramcook, Salisbury and Norton
- Static Var Compensators (SVC) in NB at Salisbury and Memramcook

Once these upgrades are completed, the “Import Power Monitor” SPS will no longer be needed under normal system conditions. IR#364 can operate without restrictions assuming that L-6513 is up-rated in 2014.

As ERIS without L-6513 up-rated IR#364 would require the establishment of significant operating restrictions while:

- NS imports 30-100 MW in summer before TSR-100 is in service,
 - High NS import (up to 300 MW before TSR-100 & up to 720 MW after TSR-100),
 - High NS export with both Trenton generators online.
- The restrictions also depend on other local generation real-time output and load demands besides NS Import/Export level.

The operating restrictions on IR#364 while NS imports 30-100 MW in summer would be eliminated after TSR-100 is in service.

The operating restrictions during summer with high NS import (up to 300 MW) would be eliminated after TSR-100 is in service; however there would also be operating restrictions required while NS imports above 540 MW associated with TSR-100 after 2016. When NS imports above 540 MW, with the addition of 50 MW by IR#364 the contingency of loss of one 345 kV transmission line from New Brunswick will cause L-6513 to exceed its conductor thermal limits. Therefore IR#364 would have to be curtailed or the NS Import would have to be reduced in order to avoid further transmission expansion requirements.

The operating restrictions while NS exports could become significant when IR#225 and IR#234 are in service (in spite of the related system upgrades), and these restrictions will be required with or without TSR-100. Otherwise the overload violations coincident with a 1N-B61 bus fault could still occur with both Trenton units generating at minimum output. Instead of the operating restrictions the potential thermal overloads could also be managed by a new Special Protection System (SPS) by tripping the wind farm coincident with a 1N-B61 bus fault. However, the new SPS scheme would have to be presented to NPCC and would require their approval.

The SIS will determine the detailed system requirements to accommodate IR#364. The requirement for restrictions or curtailments of this facility when operating with an element (transmission line, transformer etc) out of service (N-1 operation) will be further assessed in the SIS.

9 Voltage Limits

This project, like all new generating facilities must be capable of providing both lagging and leading power factor of 0.95, measured at the HV terminals of the IC Substation Step Up Transformer, at all production levels up to the full rated load of 50 MW. Data provided by the IC indicates that IR#364 may not be able to meet this requirement without additional reactive support. Based on the provided rated power factor of the Vestas V100-2.0 MW (0.95), and the provided impedances of the transformers, supplementary reactive support may be needed in the form of capacitor banks at the low voltage terminals of the Interconnection Transformer. This will be further investigated in the System Impact Study.

A centralized controller will be required which continuously adjusts individual generator reactive power output within the plant capability limits and regulates the voltage at the 34.5 kV bus voltage. The voltage controls must be responsive to voltage deviations at the terminals of the Interconnection Facility substation, be equipped with a voltage set-point control, and also have the ability to slowly adjust the set-point over several (5-10) minutes to maintain reactive power within the individual generators capabilities. The details of the specific control features, control strategy and settings will be reviewed and addressed in the SIS, as will the dynamic performance of the generator and its excitation.

The NSPI System Operator must have manual and remote control of the voltage set-point and the reactive set-point of this facility to coordinate reactive power dispatch requirements.

This facility must also have low voltage ride-through capability as per Appendix G of the Standard Generator Interconnection and Operating Agreement (GIA). The SIS will state specific options, controls and additional facilities that are required to achieve this.

10 System Security /Bulk Power Analysis

There are a number of proposed generation additions in New Brunswick that may have an impact on projects in northern NS and vice versa. Their POI, size and relative position of the NS and NB interconnection Queues will determine the impact. This will be resolved through collaboration with NBSO at the SIS stage.

The addition of 50 MW added to the system in northern Nova Scotia (between Truro and New Brunswick) could also have an impact on the ‘Export Power Monitor’ SPS, it will be further examined in the SIS study.

As NRIS this generating facility will also increase loading on the Onslow South corridor (Truro to Halifax) by replacing generation located south and west of Truro. This may require increased reactive support requirements in the Halifax area or invoke facility additions that can reduce the reactive support requirements. This will be evaluated in the SIS.

The SIS will determine if any facility changes are required to permit the proposed higher transmission loadings while maintaining compliance with NERC/NPCC standards and in keeping with good utility practice.

This generating facility is proposed to tap off L-6513 which is from 1N-Onslow to 74N-Springhill. 1N-Onslow is presently identified as a Bulk Power System (BPS) substation. BPS substations are subjected to stringent requirements for redundant and physically separated protective relay systems and tele-protection systems by NPCC. The SIS will identify if this wind facility will alter the BPS status of 1N-Onslow substation and also evaluate the BPS status of the new 138 kV interconnection substation. If the new

substation is classified as BPS, the protection systems have to be designed to NPCC Bulk Power System criteria.

11 Expected Facilities Required for Interconnection

The following facility changes are required to interconnect IR #364 onto L-6513:

Additions/Changes for POI on the 138 kV line L-6513:

1. Addition of approximately 8 km of 138kV spur line to connect the wind farm to the POI with 795 ACSR Drake conductors and a conductor thermal rating of 220 MVA,
2. Three 138kV circuit breakers and associated switches in a ring-bus arrangement and structures to turn L-6513 into a new switching station,
3. Modification on NSPI protection systems designed to NPCC Bulk Power System criteria (to be specified in the SIS),
4. Control and communications between the wind farm and NSPI SCADA system (to be specified),
5. Up-rate or Re-build L-6513 (65 km) and upgrade line terminals as required for NRIS type.

Requirements for the Generating Facility

1. 138 kV Interconnection Substation. This will include a circuit breaker at high side of customer power transformer and protections as acceptable to NSPI. An RTU to interface with NSPI's SCADA, with telemetry and controls as required by NSPI.
2. Facilities to provide 0.95 leading and lagging power factor when delivering rated output at the HV terminals of the IC Substation Step Up Transformer when the voltage at that point is operating between 95 and 105 % of nominal.
3. Centralized controls. These will provide centralized voltage set-point controls and are known as Farm Control Units (FCU). The FCU will control the 34.5 kV bus voltage and the reactive output of the machines. Responsive (fast-acting) controls are required. The controls will also include a curtailment scheme which will limit or reduce total output from the facility, upon receipt of a telemetered signal from NSPI's SCADA system.
4. NSPI to have control and monitoring of reactive output of this facility, via the centralized controller. This will permit the NSPI Operator to raise or lower the voltage set-point remotely.
5. Low voltage ride-through capability as per Appendix G to the Standard Generator Interconnection and Operating Agreement (GIA).
6. Real-time monitoring (including a Remote Terminal Unit) of the interconnection facilities.

7. Facilities for NSPI to execute high speed rejection of generation (transfer trip) if determined in SIS.

12 NSPI Interconnection Facilities and Network Upgrades Cost Estimate

Estimates for NSPI Interconnections Facilities and Network Upgrades for interconnecting 50 MW wind energy as NRIS onto the 138 kV systems are included in Table 12-1 for NRIS and Table 12-2 for ERIS.

Table 12-1: Cost Estimates identified from FEAS scope for NRIS		
	Determined Cost Items	Estimate
NSPI Interconnection Facilities		
i	Build 8 km 138kV single circuit line to L-6513	\$ 2,320,000
ii	Protection, control, communication ⁽¹⁾	\$ 1,500,000
Network Upgrades		
iii	Three 138kV circuit breakers in a ring-bus arrangement	\$4,629,000
iv	Up-rate L-6513 (65 km)	\$8,125,000
v	Line L-6513 terminal upgrades at 1N-Onslow and 74N-Springhill	\$400,000
Totals		
vi	Contingency (10%)	\$1,697,400
vii	Total of Determined Cost Items	\$18,671,400
To be Determined Costs		
viii	System additions to address potential stability limits	TBD (SIS)

(1) This study assumes the protection designed to the NPCC Bulk Power System criteria. To be specified in the SIS and FAC study.

The preliminary non-binding cost estimate for interconnecting 50 MW onto L-6513 as NRIS would be \$18,671,400 including a contingency of 10%. The Interconnection Customer is also required to fund the Item iii), iv) and v) costs, but would be eligible for repayment in accordance with the terms of the GIA.

Table 12-2: Cost Estimates identified from FEAS scope for ERIS		
	Determined Cost Items	Estimate
NSPI Interconnection Facilities		
i	Build 8 km 138kV single circuit line to L-6513	\$ 2,320,000
ii	Protection, control, communication ⁽²⁾	\$ 1,500,000
Network Upgrades		
iii	Three 138kV circuit breakers in a ring-bus arrangement	\$4,629,000
Totals		
vi	Contingency (10%)	\$844,900
vii	Total of Determined Cost Items	\$9,293,900
To be Determined Costs		
viii	System additions to address potential stability limits	TBD (SIS)

(2) This study assumes the protection designed to the NPCC Bulk Power System criteria. To be specified in the SIS and FAC study.

The preliminary non-binding cost estimate for interconnecting IR#364 onto L-6513 as ERIS with operating restrictions would be \$9,293,900 including a contingency of 10%, and the cost estimates does not include the network upgrades on L-6513. The Interconnection Customer is also required to fund the Item iii) cost, but would be eligible for repayment in accordance with the terms of the GIA.

13 Issues to be addressed in SIS

The following provides a preliminary scope of work for the subsequent SIS for IR#364. The SIS will include a more comprehensive assessment of the technical issues and requirements to interconnect generation as requested. It will include contingency analysis, system stability and ride through and operation following a contingency (N-1 operation). The SIS must determine the facilities required to operate this facility at full capacity, withstand any contingencies (as defined by the criteria appropriate to the location) and identify any restrictions that must be placed on the system following a first contingency loss. The SIS will confirm the options and ancillary equipment that the customer must install to control flicker, voltage and ensure that the facility has the required ride-through capability. The SIS will be conducted in accordance with the GIP with the assumption that all appropriate higher-queued projects will proceed and the facilities associated with those projects are installed. The SIS will identify if this wind facility will alter the BPS status of 1N-Onslow substation and also evaluate the BPS status of the new 138 kV interconnection substation. If the new substation is classified as BPS, the protection systems have to be designed to NPCC Bulk Power System criteria.

Control Centre Operations – Interconnection Feasibility Optional Study Report

The following outline provides the minimum scope that must be completed in order to assess the impacts. It is recognized the actual scope may deviate, to achieve the primary objectives.

The assessment will consider but not be limited to the following.

- i. Facilities that the customer must install to meet the requirements of the GIP
- ii. The minimum transmission additions/upgrades that are necessary to permit operation of this Generating Facility, under all dispatch conditions, catering to the first contingencies listed.
- iii. Guidelines and restrictions applicable to first contingency operation (curtailments etc)
- iv. System loss impacts
- v. Under-frequency load shedding impacts

To complete this assessment the following first contingencies, as a minimum, will be assessed:

- L-8001/3025
- L-3006 – with and without NBPT SPS operation
- Memramcook 345/138 kV transformer
- L-6513
- L-6514
- L-6535/L-1159
- L-6536/L-1160
- L-8003
- L-8002 & L-8003 (common circuit breaker)
- L-8003 & L-8004 (common circuit breaker)
- L-8001 & 67N-T81 TX (common circuit breaker)
- L-8002 & 67N-T81 TX (common circuit breaker)
- L-3006 & L-3025 & Memramcook 345/138 kV Tx (common breaker)
- L-3006 & L3017 (common breaker)
- 1N-B61
- L-1108/1190 Common 138kV structure
- Loss of 180 MW of load under peak load conditions and 250 MW under light load conditions
- Loss of largest generation – Pt. Aconi 174MW net
- Loss of two generating units at Lingan – 312 Net
- Loss of the Trenton Bus (Two units with load)

To complete this assessment the dynamics of the following first contingencies, as a minimum, will be assessed:

- 3 phase fault L-8001/3025 at 67N-Onslow, NS Import SPS operation (islanding)

Control Centre Operations – Interconnection Feasibility Optional Study Report

- 3 phase fault L-3006 at Memramcook, NB SPS/UVLS operation (islanding)
- 3 phase fault L-3006 at Salisbury, NB SPS/UVLS operation (islanding)
- 3 phase fault L-8003 at 67N-Onslow
- 3 phase fault L-8002 at 67N-Onslow
- Slg L-3017, drops L-3017&L-3006 (common CB), NB SPS/UVLS operation,
- Slg Memramcook T3, drops L-3006 (common CB), NB SPS/UVLS operation
- Slg L-8002 at Onslow, drops L-8003, Grp5 SPS Operation
- 3 phase fault at 79N-Hopewell, drops L-8003, 8004, bus, SPS operation
- 3 phase fault 1N-Onslow 138 kV bus B61
- 3 phase fault 74N-Springhill 138 kV bus

Any changes to SPS schemes required for operation of this generating facility, in addition to existing generation and facilities that can proceed before this project, will be determined by the SIS as well as any required additional transmission facilities. The determination will be based on NERC² and NPCC³ criteria as well as NSPI guidelines and good utility practice. The SIS will also determine the contingencies for which this facility must be curtailed.

The SIS will calculate the unit loss factor, which is a measure of the percentage of the net output of IR #364 which is lost through the transmission system. Preliminary value is calculated to be 4.2% (system losses increased by net 2.1 MW when IR #364 is operated at 50 MW).

Nova Scotia Power
2012-02-28

² NPCC criteria are set forth in it's Reliability Reference Directory #1 *Design and Operation of the Bulk Power System*

³ NERC transmission criteria are set forth in *NERC Reliability Standards TPL-001, TPL-002, TPL-003*